

(19) World Intellectual Property Organization  
International Bureau



(43) International Publication Date  
8 April 2004 (08.04.2004)

PCT

(10) International Publication Number  
WO 2004/028608 A1

(51) International Patent Classification: A61M 15/00

(11) International Application Number: PCT/US2003/029356

(12) International Filing Date: 15 September 2003 (15.09.2003)

(15) Filing Language: English

(24) Publication Language: English

(30) Priority Data: 0222295 A 25 September 2002 (25.09.2002) GB

(71) Applicant (for all designated States except US): 3M INNOVATIVE PROPERTIES COMPANY (USAS); 3M Center, P.O. Box 33427, Saint Paul, MN 55133-3427 (US).

(72) Inventors and (75) Inventor/Applicants (for US only): MAHON, Gary, D.

([BR/FR]): 122 The Downs, Silverdale, Willford, Nottinghamshire NG11 7YF (GB); BAUM, Eric, A. (GB/GB); 34 Shepherds Close, Loughborough, Leicestershire LE11 3LA (GB); BRYANT, Andrew, M. (GB/GB); 9, Old North Road, Basalbhoun cum Knesworth Cambridgeshire SG8 3JG (GB).

(74) Agents: RINGSRED, Ted, K. et al.; Office of Intellectual Property Counsel, P.O. Box 33427, Saint Paul, MN 55133-3427 (US).

(83) Designated States (national): AH, AG, AL, AM, AT (utility model), AU, AZ, BA, BB, BG, BR, BY, BZ, CA, CH, CN, CO, CR, CU, CZ (utility model), DE (utility model), DK, DM, DZ, EC, EE (utility model), EG, ES, FI (utility model), FI, GB, GD, GH, GI, GM, GN, GR, HU, ID, IL, IN, IS, JP, KE, KG, KP, KR, KZ, LC, LR, LS, LT, LU, LV, MA, MD, MG, MK, MN, MW, MX, MY, NI, NG, NZ, OM, PA, PE, PG, PH, PL, PT, RO, RU, SC, SD, SE, SG, SK (utility model), SK, SL, SY, TI,

(Continued on next page)



TM, TN, TR, TT, TZ, UA, UG, US, UZ, VC, VN, YU, ZA, ZM, ZW.

SI, SJ, SK, TR), OAPI patent (BF, BJ, CF, CG, CI, CM, GA, GN, GQ, GW, ML, MR, NE, SN, TD, TG).

Published: with international search report

(84) Designated States (regional): ARIPO patent (GH, GM, KE, LS, MW, MZ, SD, SL, SZ, TZ, UG, ZM, ZW); Eurasian patent (AM, AZ, BY, KG, KZ, MD, RU, TJ, TM); European patent (AT, BE, BG, CH, CY, CZ, DE, DK, EE, ES, FI, FR, GB, GR, HU, IE, IT, LU, MC, NL, PT, RO,

For two-letter codes and other abbreviations, refer to the "Guidance Notes on Codes and Abbreviations" appearing at the beginning of each regular issue of the PCT Gazette.

(54) Title: BREATH-ACTUATED AEROSOL DISPENSERS

(57) Abstract: A breath actuated metered dose inhaler device for use with an actuated valve having a transient metering chamber.

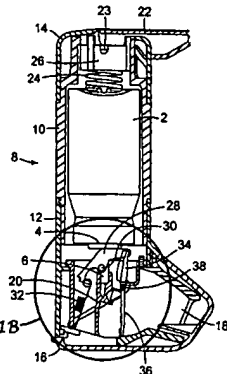

WO 2004/028608 A1

WO 2004/028608

PCT/US2003/029356

WO 2004/028608

PCT/US2003/029356

BREATH-ACTUATED MEDICAMENT DISPENSING DEVICES

This invention relates to breath actuated medicament dispensing devices of the type where a metered dose of medicament is administered to the respiratory system of a patient in response to the inhalation of the patient.

Metering valves are a common means by which aerosols are dispensed from aerosol containers. Metering valves are particularly useful for administering medicinal formulations that include a liquefied gas propellant and are delivered to a patient in an aerosol.

In some metering valves, the metering chamber fills with the medicinal formulation prior to the patient actuating the valve stem and thereby releasing the dose. The metering chamber is refilled with formulation after dispensing one dose so that the metering valve is ready to discharge the next dose. Consequently, the metering chamber contains formulation at all times except for the brief time during which the valve stem is depressed by the user to discharge a dose.

In other metering valves the metering valve is designed such that the metering chamber does not materialize unless and until the valve stem is actuated. Examples of such valves are disclosed in U.S. 4,819,834. Actuation of these valve stems can be divided into a filling stage and a discharge stage. The filling stage begins as the valve stem is depressed during actuation. The action of depressing the valve stem causes the formation of a transient metering chamber, which is in fluid communication with the residual metering volume defined by the small annular gap. As the valve stem is depressed, the transient portion of the metering chamber expands and formulation enters the metering chamber. As displacement of the valve stem continues, a stage is reached at which filling of the transient metering chamber stops.

Eventually, displacement of the valve stem continues to the discharge stage, in which the metered formulation is discharged. In these valves, a single actuation thus causes rapid filling of the transient metering chamber followed by discharge of the formulation to the patient. Generally, metered formulation does not reside for any appreciable amount of time in the metering chamber in these metering valves.

While a metering valve having a transient metering chamber provides advantages over other types of metering valves for the delivery of aerosol formulations, it has now been appreciated that the flow of formulation from the container to the metering chamber may be disrupted or impeded. Flow through regions of significantly restricted access, such as narrow annular passageways and/or entrance ways to the metering chamber, may be impeded sufficiently to give rise to substantially incomplete filling of the metering chamber. If this happens, formulation may be delivered in inconsistent or inaccurate doses. In particular, it has now been appreciated that the time available for filling the metering chamber also has a significant effect on the ability to completely fill the transient metering chamber. The time available for filling depends on the speed at which the valve stem is depressed. In the so-called "preas-end-breathe" devices in which the patient manually depresses the aerosol container relative to the valve stem to fire the valve the speed at which the valve stem is depressed is generally not more than 100mm/sec. However, breath actuated inhalers typically fire the valve more rapidly than manual firing e.g. with valve stem speeds in the range 165 to 330 mm/sec. Thus, there are difficulties associated with the use of metering valves having a transient metering chamber with breath actuated devices.

A common feature of many known breath actuation devices is that they involve two stages of operation: a priming stage in which a priming force is applied to the valve stem but actuation of the valve stem is prevented, and a firing stage in which the priming force is released resulting in movement of the valve stem to fire the valve. The priming stage is generally a manual operation and may involve some movement of the valve stem but not sufficient to fire the valve. Any movement of the valve stem in the priming stage tends to

be at relatively low speed. Once the device is triggered by inhalation there is high speed displacement of the valve stem under the priming force.

It has now been found that if the metering and firing stages of operation of a metering valve of the type having a transient metering chamber are synchronised with the priming and firing stages of a breath actuated device, any difficulties or problems associated with flow of formulation to fill the metering chamber may be overcome or at least significantly reduced.

Therefore according to the present invention there is provided a breath actuated medicament dispensing device comprising:

an aerosol container containing a pressurised medicament formulation equipped with a metered dose dispensing valve having a movable valve stem;

a housing disposed about the aerosol container;

a patient port in communication with the dispensing valve;

priming means adapted to apply a bias to the valve stem relative to the aerosol container sufficient to move the valve stem to fire the valve; restraining means

movable between a blocking position in which it prevents said bias firing the valve and a release position in which it allows said bias to fire the valve;

trigger means responsive to inhalation through the patient port to cause the

restraining means to move from its blocking position to its release position; wherein the aerosol valve comprises:

a valve housing;

a tank component positioned within the valve housing; and

a valve stem mounted within said valve housing and tank component sequentially movable between a first position, a second position and a third position as the valve stem is depressed in a single direction;

such that:

as the valve stem is moved from said first position towards said second position a metering chamber is formed and defined between the valve stem and tank component and formulation flows from the aerosol container into the metering chamber;

3

sufficient to form and completely fill the metering chamber in the valve. The valve is held in its second position until the device is actuated by the patient inspiring through the patient port. Patient inspiration actuates the trigger which allows movement of the restraining means to its release position and thereby allows relative movement of the valve stem and aerosol container under the influence of the bias causing the valve to fire.

In another embodiment of the invention the aerosol container is fixed within the housing and the priming force is applied to the valve stem e.g. to a movable nozzle block which is mounted on the valve stem.

The invention will now be described with reference to the accompanying drawings in which:

Figure 1A represents a vertical cross-section through an embodiment of a dispensing device in accordance with the invention in its first position,

Figure 1B shows the restraining and triggering means of the device and

Figure 1C is a cross-section through the aerosol valve in its first position;

Figures 2A, 2B and 2C represent similar views to Figure 1 with the device in its primed position and the aerosol valve in its second position; and

Figure 3A shows the device of Figure 1 in its fired position and

Figure 3B shows the aerosol valve in its third (fired) position.

The invention will be described with reference to a breath actuated device which is described in EP 0147028. However, it will be appreciated that the invention may use other variants of breath actuated devices, such as those described in GB 1288971, GB 1297993, GB 1335378, GB 1383761, GB 1392192, GB 1413285, WO85/01880, GB 2204799, US 4,803,978, EP 0186280, GB 1269554, US 5,447,150 and WO 01/93933.

5

in said second position the metering chamber has a predetermined volume and is sealed from the aerosol container; and

in said third position formulation is released from the metering chamber through the valve stem;

and wherein:

the priming means is constructed and arranged such that as the device is primed by operating said priming means the valve stem is moved from its first to its second position to allow formation and filling of the metering chamber;

the restraining means is constructed and arranged such that in its blocking position it maintains the valve stem in its second position until the trigger means is actuated by inhalation through the patient port.

The invention provides a simple effective means of overcoming problems associated with filling the metering chamber of an aerosol valve of the type having a transient metering chamber by controlling the movement of the valve stem from its first to second position by the priming and restraining means of a breath actuated device. When the breath actuated device has been primed the valve stem is held in its second position with the metering chamber completely full of formulation ready to be dispensed. The priming stage of the breath actuated device is sufficiently slow to allow the metering chamber to be filled as it is created by movement of the valve stem.

The invention is applicable to a wide range of breath actuated devices including those in which the restraining means comprises a latch mechanism and those in which the restraining means comprises means for applying a resisting pneumatic force.

In general, the aerosol container will be mounted in the dispensing device with the valve stem located in a fixed nozzle block. A priming force is applied to the base of the aerosol container e.g. by compression of a spring. When the device is primed by compressing the spring e.g. by moving a lever to an over centre position, there is movement of the aerosol container relative to the valve stem causing the valve stem to be partially depressed before the restraining means is engaged to prevent further movement. The device is arranged such that this initial movement of the valve stem relative to the aerosol container is

4

In the drawings, like references represent like parts.

Figure 1A shows a cross section through a breath actuated device in its rest position. The device comprises an aerosol container (2) containing a pressurised medicament formulation and equipped with a metered dose dispensing valve (4) having a movable valve stem (6). A housing (8) is disposed about the aerosol container (2) and comprises a sleeve (10), body (12), top (14) and a mouthpiece cover (16) which covers the patient port (18). The valve stem (6) is positioned within a nozzle block (20) which directs formulation from the valve stem towards the patient port (18).

The priming means comprises a priming lever (22) which is pivotally mounted about axis (23) to act upon priming spring (24) secured within a cage (26). In the rest position shown in Figure 1A, the priming spring (24) exerts little or no bias on the aerosol container (2).

The restraining means comprises a rocker (28) pivotally mounted about axis (30). One end of the rocker is attached to tension spring (32) and the other is pivotally connected to catch (34). The other end of catch (34) rests on a cam surface of vane (36) which acts as the trigger mechanism. Vane (36) is pivotally mounted at axis (38).

In the rest position shown in Figure 1B there is a clearance (40) between the upper surface (42) of the rocker (28) and the lower surface (44) of the valve ferrule.

6

Figure 1C is on an enlarged scale compared with Figure 1A and shows a cross-section through the aerosol valve in its first position when the device is in its rest position as shown in Figure 1A.

The valve (4) comprises a valve housing (46), a tank component (48) positioned within the valve housing and a valve stem (6) mounted within the valve housing and tank component. The valve comprises outer seal (50) and inner seal (52). The valve stem (6) is biased towards its first position shown in Figure 1C by compression spring (54) held within spring retaining sleeve (56).

The outer portion of the valve stem (6) comprises a discharge passage (58) and side pierce (60). The inner portion of the valve stem is shaped to completely fill the tank component (48) when the valve stem is in its first position. The inner portion of the valve stem is hollow, in communication with the aerosol container and comprises sampling ports (62). When the valve stem is in its first position shown in Figure 1C there is no metering chamber formed.

Figures 2A and 2B show the device in its primed position. Priming lever (22) is pivoted upwardly causing spring (24) to be compressed applying a bias to the aerosol container (2). The aerosol container moves downwardly under the influence of the bias until the lower surface (44) of the valve ferrule contacts the upper surface (42) of the rocker (28). The rocker (28) is unable to pivot since it is blocked by the catch (34) that engages the vane (36). During the priming operation the aerosol container moves by the distance of the clearance (40) shown in Figure 1B.

During the priming operation the valve moves from its first position shown in Figure 1C to its second position shown in Figure 2C. During movement of the valve stem from its first to its second position a metering chamber (64) is formed between the inner portion of the valve stem (6) and the tank component (48). The metering chamber is filled with formulation from the aerosol container passing through the sampling port (62) and through a small annular gap (not shown) between the inner portion of the valve stem (6)

7

It will be understood that the present disclosure of particular embodiments in accordance with the invention is for the purpose of illustration only and the invention extends to modifications, variations and improvements thereof.

9

and the tank component (48) into the metering chamber (64). Formulation is prevented from exiting the metering chamber (64) by the outer seal (50) that is in sealing engagement with the valve stem and between the tank component (48) and the valve housing (46). In the second position of the valve stem shown in Figure 2, inner seal (52) is in sealing engagement with the valve stem thereby preventing formulation passing through the sampling port (62). In the second position of the valve stem shown in Figure 2C the metering chamber has been fully formed and completely filled with the formulation.

Figure 3A shows the device in its fired position. Inhalation through the patient port (18) causes vane (36) to pivot upwardly. Movement of the vane (36) displaces the end of catch (34) from the vane thereby moving the constraint on rocker (28). Rocker (28) pivots due to the force exerted on it by the valve ferrule under the influence of the priming spring (24) thereby allowing the aerosol container (2) to move downwardly, causing the valve to fire.

Figure 3B shows the valve in its firing position. The valve stem (6) has moved inwardly such that the side pierce (60) passes through the outer seal (50) thereby allowing the contents of the metering chamber to pass through the side pierce (60) and discharge passage (58). The inner seal (52) remains in sealing engagement with the inner portion of the valve stem preventing communication between the metering chamber (64) and the aerosol container.

It will be appreciated that the speed of movement during the firing, i.e. movement of the valve stem from its second to its third position, will not affect the performance of the valve since the metering chamber was formed and completely filled during the priming stage. Thus high speed movement under the influence of the priming spring during the firing operation has no effect on the volume of formulation dispensed.

8

#### CLAIMS

1. A breath actuated medicament dispensing device comprising:
  - an aerosol container containing a pressurised medicament formulation equipped with a metered dose dispensing valve having a movable valve stem;
  - a housing disposed about the aerosol container;
  - a patient port in communication with the dispensing valve;
  - priming means adapted to apply a bias to the valve stem relative to the aerosol container sufficient to move the valve stem to fire the valve;
  - restraining means movable between a blocking position in which it prevents said bias firing the valve and a release position in which it allows said bias to fire the valve;
  - trigger means responsive to inhalation through the patient port to cause the restraining means to move from its blocking position to its release position;
- 15 wherein the aerosol valve comprises:
  - a valve housing;
  - a tank component positioned within the valve housing; and
  - a valve stem mounted within said valve housing and tank component sequentially movable between a first position, a second position and a third position as the valve stem is depressed in a single direction;
  - 20 such that:
    - as the valve stem is moved from said first position towards said second position a metering chamber is formed and defined between the valve stem and tank component and formulation flows from the aerosol container into the metering chamber;
    - 25 in said second position the metering chamber has a predetermined volume and is sealed from the aerosol container; and
    - in said third position formulation is released from the metering chamber through the valve stem;
  - and wherein:
    - 30 the priming means is constructed and arranged such that as the device is primed by operating said priming means the valve stem is moved from its first to its second position to allow formation and filling of the metering chamber;

10

the restraining means is constructed and arranged such that in its blocking position it maintains the valve stem in its second position until the trigger means is actuated by inhalation through the patient port.

- 2. A breath actuated medicament dispensing device as claimed in Claim 1 in which the priming means comprises a spring.
- 3. A breath actuated medicament dispensing device as claimed in Claim 1 or Claim 2 in which the valve stem is located within a nozzle block and the priming means applies a bias to the aerosol container.
- 4. A breath actuated medicament dispensing device as claimed in any preceding claim in which the restraining means comprises a latch and the triggering means comprises a vane.
- 5. A breath actuated medicament dispensing device as claimed in Claim 4 in which the vane is positioned within the patient port.
- 6. A breath actuated medicament dispensing device as claimed in any one of Claims 1 to 3 in which the restraining means comprises means for applying a resisting pneumatic force to prevent firing of the valve under the influence of the priming means.

25

11

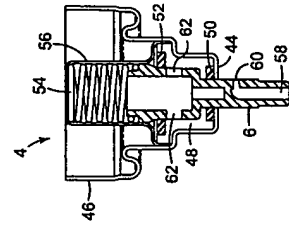

FIG. 1C

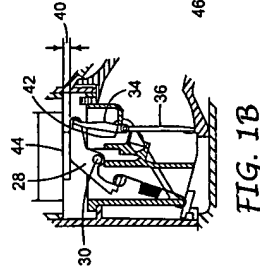

FIG. 1B

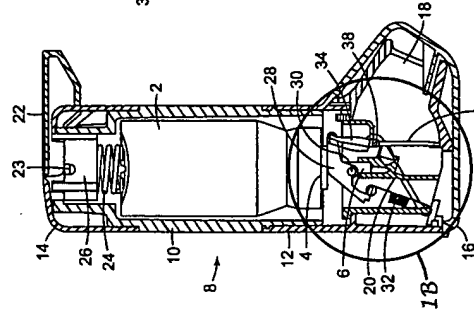

FIG. 1A

1/3

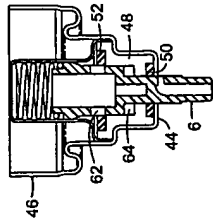

FIG. 2C

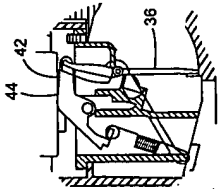

FIG. 2B

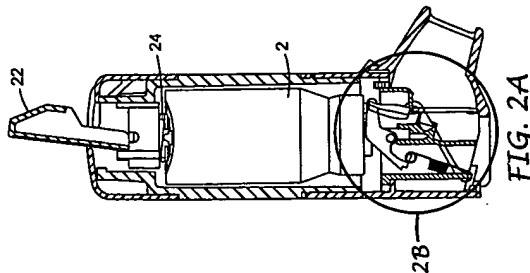

FIG. 2A

2/3

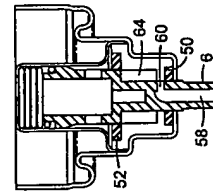

FIG. 3B

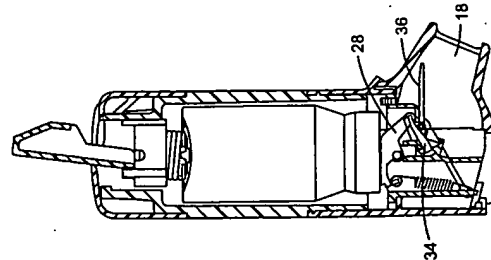

FIG. 3A

3/3

INTERNATIONAL SEARCH REPORT

International Application No  
PCT/US 03/29356

CLASSIFICATION OF SUBJECT MATTER IPC 7 A61M15/00	
According to International Patent Classification (IPC) or to both national classification and IPC	
B. FIELDS SEARCHED Electronic document(s) searched (classification system followed by classification symbols) IPC 7 A61M	
Documentation searched other than electronic documentation to the extent that such documents are included in the fields searched	
Electronic data base consulted during the international search (name of data base and, where practical, search terms used) EPO-Internal	
C. DOCUMENTS CONSIDERED TO BE RELEVANT	
Category *	Relevant to claim No.
X	1-6
A	
A	
A	
<input type="checkbox"/> Further documents are listed in the continuation of box C. <input checked="" type="checkbox"/> Patent family members are listed in annex.	
* Special categories of cited documents: "A" document defining the general state of the art which is not considered to be of particular relevance "E" earlier document but published on or after the international filing date "L" document which may throw doubts on priority claim(s) or which is cited to establish the publication date of another claim or other special interest (as specified) "O" document referring to an oral disclosure, use, exhibition or other means "P" document published prior to the international filing date but later than the priority date claimed "T" later document published after the international filing date or priority date and not in conflict with the application but cited to understand the principle or theory underlying the invention "X" document of particular relevance: the claimed invention cannot be considered novel or cannot be considered to include an inventive step unless the document is taken alone "Y" document of particular relevance: the claimed invention cannot be considered to involve an inventive step when the document is combined with one or more other such documents, such combination being obvious to a person skilled in the art. "Z" document member of the same patent family	
Date of the actual completion of the international search 7 January 2004	Date of mailing of the international search report 14/01/2004
Name and mailing address of the ISA European Patent Office, P.O. Box 2911 Patentstrasse 2 NL - 2000 RB The Hague Tel: (+31-70) 340-2040, Tx: 81 651 apo nl, Fac: (+31-70) 340-2010	Authorized officer Zelstra, H

INTERNATIONAL SEARCH REPORT

Information on patent family members

International Application No  
PCT/US 03/29356

Patent document cited in search report	Publication date	Patent family member(s)	Publication date	
EP 0147028	A	03-07-1985	AU 578915 B2	10-11-1988
			AU 3558384 A	22-01-1985
			CA 1236359 A1	10-05-1988
			DE 3470844 D1	09-06-1988
			EP 0147028 A1	03-07-1985
			FI 852490 A , B,	24-05-1985
			JP 5048138 B	20-07-1993
			JP 6150254 T	20-02-1986
			WO 8501890 A1	09-05-1985
			US 4664107 A	12-05-1987
			US 5826571	A
EP 1019125 A1	19-07-2000			
US 2002100472 A1	01-08-2002			
US 6357442 B1	19-03-2002			
AU 732859 B2	03-05-2001			
AU 3743297 A	22-02-1999			
CA 2295589 C	02-07-2002			
JP 2001511401 T	14-08-2001			
WO 9628367	A	19-09-1996	AU 698364 B2	29-10-1998
			AU 5185396 A	02-10-1996
			CA 2213442 A1	19-09-1996
			DE 69609315 D1	17-09-2000
			DE 69609315 T2	15-02-2001
			EP 0813490 A2	29-12-1997
			EP 0870699 A2	14-10-1998
			JP 11501892 A	16-02-1999
			WO 9628367 A2	19-09-1996
			US 5772085 A	30-06-1998